



# F1522 - 1500lb Flake Ice Machine

Prodigy Plus® Flake Ice Machine

## Superior performance with every cup.

Now the soft, chewable flake ice that customers love is available with more innovative technology than ever before. With next-generation diagnostics like AutoAlert™ indicator lights on the new Scotsman Prodigy Plus® flake ice machines, operators can help ensure superior performance while enjoying maximum efficiency — every day. And with features like advanced ice level control, a small operational footprint and easy-access service from the front panel, Prodigy Plus® flake ice machines are the smart choice for today's busy food-service environments.



## The Prodigy Plus® difference.

- AutoAlert™ indicator lights for better visibility
- Operational footprint among the industry's smallest
- Industry-exclusive QR code instantly connects users to service information and warranty history
- Front-located air filter for more efficient operation
- Self-aligning front panel for easy access to key components
- Smart-Board™ advanced feature module available for additional diagnostic capabilities
- Optional Vari-Smart™ ice level control allows operators to customize ice levels
- Antimicrobial protection guards internal surfaces between cleanings
- A full range of water- and energy-saving features



## 24 Hour Volume Production

### Air Cooled

70°F/21°C	Air	90°F/32°C
50°F/10°C	Water	70°F/21°C
1570/712		1100/499
lb/kg		lb/kg



## Modular Bin Options



F1522 side by side on B948S

Model Number*	Dimensions W" x D" x H"	AHRI Certified Bin Capacity lb/kg	Finish	Ship Weight lb/kg
B948S	48 x 34 x 44**	700/319	Metallic	220/100
BH1100BB-A	48 x 34 x 50**	860/390	SS w/ GBB†	280/127
BH1100SS-A	48 x 34 x 50**	860/390	Stainless Steel	280/127
BH1300BB-A	60 x 34 x 50**	1100/499	SS w/ GBB†	310/140
BH1300SS-A	60 x 34 x 50**	1100/499	Stainless Steel	310/140
BH1600BB-A	60 x 34 x 62**	1375/624	SS w/ GBB†	370/168
BH1600SS-A	60 x 34 x 62**	1375/624	Stainless Steel	370/168

\*Contact Scotsman for bin top requirements. \*\*Add 6" Height for bin legs.  
† Stainless steel with galvanized back & bottom.



## Flake Ice



Cools more quickly than other ice forms. Ideal for seafood and produce displays.



## Certification



## Warranty

- 3 years parts and labor on all components.
- 5 years parts on the compressor.
- Warranty valid in North, South & Central America for commercial installations.
- Contact factory for warranty in other regions.

F1522 - 1500lb Flake Ice Machine



# F1522 - 1500lb Flake Ice Machine

Prodigy Plus® Flake Ice Machine

F1522 - 1500lb Flake Ice Machine

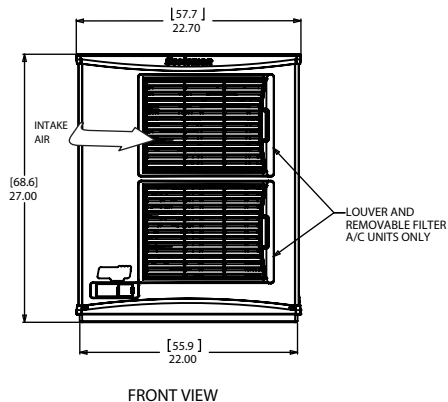
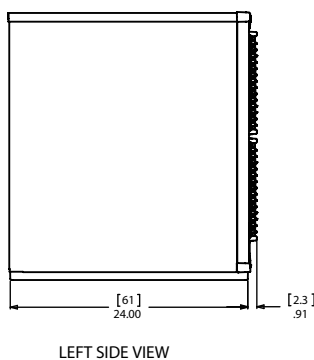
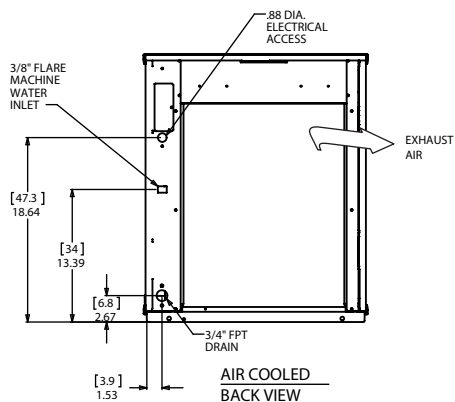
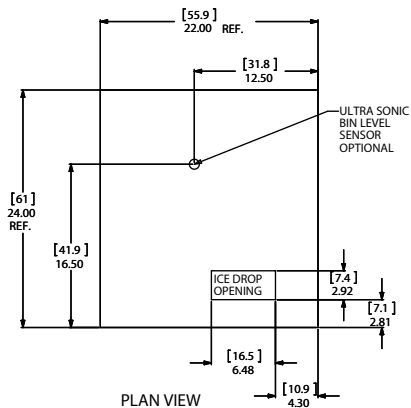

## Specifications

Model Number	Condenser Unit	Basic Electrical Volts/Hz/Phase	Max. Fuse Size (amps)	Circuit Wires	Min. Circuit Ampacity	Energy Consumption kWh/100 lb (45.4 kg) 90°F(32°C)/70°F(21°C)	Water Usage Gallons/100 lb (liters/45.4 kg)	
							Potable	Condenser
F1522A-32	Air	208-230/60/1	30	2	19.1	3.7	12.0/45.5	-



## All Models

### Dimensions (W x D x H):

Unit: **Individual**  
22.9" x 24" x 27"  
(58.2 x 61.0 x 68.6 cm)

**Side by Side**  
45.8" x 24" x 27"  
(116.3 x 61.0 x 68.6 cm)

Shipping Carton: 25.5" x 27.5" x 32.5"  
(64.8 x 69.9 x 82.6 cm)

Shipping Weight: 224 lb / 102 kg  
BTUs per hour: 16,000

Refrigerant: R-404A



## Accessories

Model Number	Description
KVS	Vari-Smart™ Ice Level Control - Program ice bin levels to match ice needs.
KSBU	Smart-Board™ Advanced Control - Use additional operational data for fast diagnosis.
KSBU-N	Smart-Board™ Advanced Control with Network - Network capable.
KPAS	Prodigy Advanced Sustainability Kit - Includes KVS and KSBU - N

Scotsman recommends all ice machines have water filtration. See Scotsman water filter specification sheet for details.



## Operating Requirements

	Minimum	Maximum
Air Temperatures	50°F (10°C)	100°F (38°C)
Water Temperatures	40°F (4.4°C)	100°F (38°C)
Remote Cond. Temps	-20°F (-29°C)	120°F (49°C)
Water Pressures	20 PSIG (1.4 bar)	80 PSIG (5.5 bar)
Electrical Voltage	-5%	+10%

Specifications and design are subject to change without notice.

• 101 Corporate Woods Parkway, Vernon Hills, IL 60061 •

• 1-800-SCOTSMAN • Fax: 847-913-9844 • www.scotsman-ice.com • customer.relations@scotsman-ice.com •

© 2017 Scotsman Ice Systems.

# Scotsman®

SIS-SS-PP-F1522 01-17